



Bridge Expansion Joints



INTRODUCTION

Modular Expansion Joint system

The Modular Expansion Joint System (MEJS) is a mechanical device installed in bridge expansion joint openings. The primary function of the MEJS is to permit vehicle traffic to travel smoothly across large expansion joint openings. It does this by dividing the large expansion joint openings into a series of smaller openings called cells. These cells work in series to accommodate the necessary thermal bridge movement (expansion and contraction) while providing a smooth riding surface for bridge vehicle traffic. The MEJS is normally used for expansion joints with a movement range exceeding 75 mm.

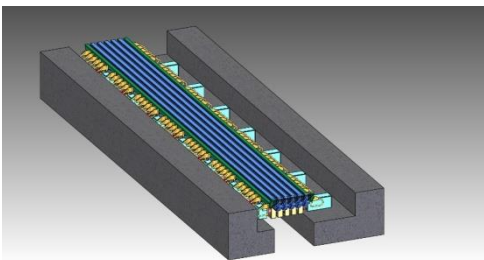

Figure 1- MEJS joints

The MEJS also has the secondary function of protecting the surrounding bridge superstructure and substructure. All MEJS cells are equipped with watertight sealing elements that prevent debris, water, and corrosives such

as de-icing chemicals from passing through bridge expansion openings and damaging superstructure and substructure.

Modular Expansion Joint with Skew

Because bridge expansion joints open and close in the direction of traffic, a bridge skew or radius creates movement that is not parallel to the normal movement of the MEJS. If the direction of movement of the MEJS is not perpendicular to the joint axis but skewed with the angle β (Figure 2), We designs the MEJS to handle the respective transverse movement.

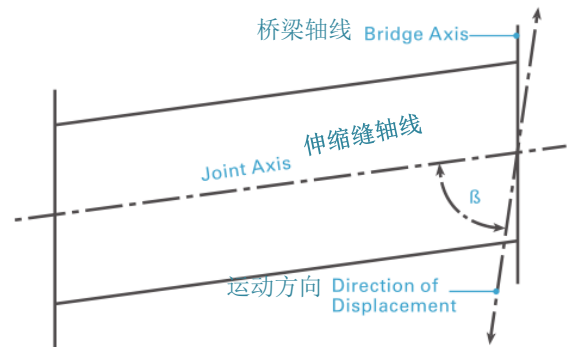

Figure 2- skewed direction of movement

Note: The direction of movement does not, in each case, have to be identical to the movement of the bridge axis.

SUPPORT SYSTEM AND COMPONENTS

Physical Data

Movement range – The movement range of the MEJS is accommodated by the planned operating range of the neoprene seal and by the number of seals. That is, if the planned operating range of the neoprene seal equals 80 mm, the IG12 MEJS achieves a movement range of 960 mm (12 × 80 mm = 960 mm).

Joint Width – The joint width “f” (Figure 3) is variable. It changes with MEJS movement. Joint width f min is the width

Of a closed joint. Joint widths f 60 , f 70 , and f 80 are the widths of the fully open joint. That is, each element has a gap of 60 mm, 70 mm, 80 mm according to the planned operating range. Thus for an IG6 MEJS, there is a difference between fmin and f80 of 480 mm (6 × 80 mm = 480 mm)。

Weight – The MEJS weights “G” shown in Figure 3 are mean values that vary, depending on design details.

Type	b1		b2		h		f _{min}		f ₆₀		f ₇₀		f ₈₀		G(Wt)	
	mm	in	mm	in	mm	in	mm	in	mm	in	mm	in	mm	in	kg/m	lbs/ft
LG2	400	15.7	300	11.8	400	15.7	130	5.1	250	9.8	270	10.6	290	11.4	150	99
LG3	480	18.9	300	11.8	400	15.7	210	8.3	390	15.4	420	16.5	450	17.7	210	139
LG4	560	22	300	11.8	400	15.7	290	11.4	530	20.9	570	22.4	610	24	250	165
LG5	640	25.2	300	11.8	400	15.7	370	14.6	670	26.4	720	28.3	770	30.3	290	195
LG6	720	28.3	300	11.8	400	15.7	450	17.7	810	31.9	870	34.3	930	36.6	410	275
LG7	800	31.5	300	11.8	420	16.5	530	20.9	950	37.4	1020	40.2	1090	42.9	500	335
LG8	880	34.6	300	11.8	440	17.3	610	24	1090	42.9	1170	46.1	1250	49.2	596	400
LG9	960	37.8	300	11.8	450	17.7	690	27.2	1230	48.4	1320	52	1410	55.5	745	500
LG10	1040	41	300	11.8	460	18.1	770	30.3	1370	53.9	1470	57.9	1570	61.8	1060	713
LG12	1200	47.2	300	11.8	500	19.7	930	36.6	1650	65	1770	69.7	1890	74.4	1340	900

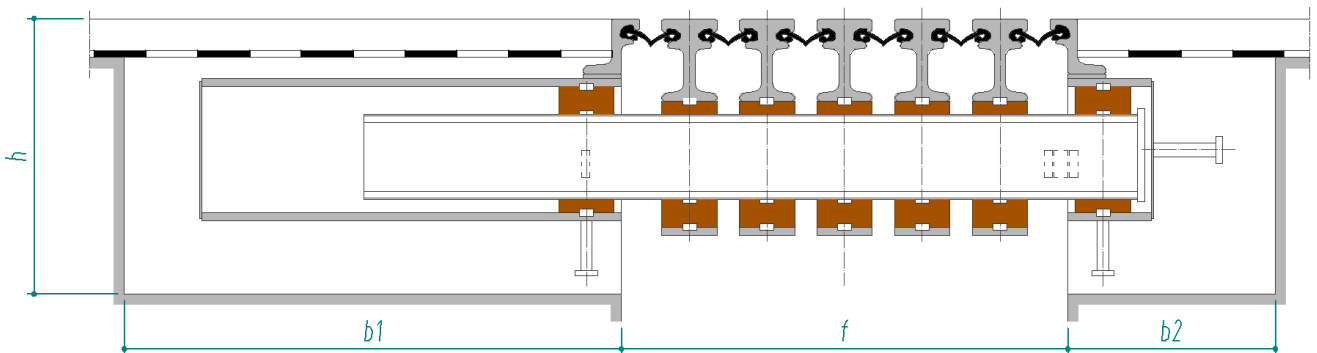

Figure 3 – Modular Expansion Joint types and sizes

SUPPORT SYSTEM AND COMPONENTS







Component								
Description	Center beam/ Support bar	Edge Beam	Slide Spring	Slide Bearing	Support Bar Box	Control Spring	Strip Seal Gland	Center Beam Bracket
Material	ASTM A572, A588 DIN ST52-3 GB/T1591-2008	ASTM A572, A588 DIN ST52-3 GB/T1591-2008	Natural Rubber /PTFE	Nylatron	ASTM A 500, A 36, A 572 GB/T 700-2006	Polyurethane Foam/ 55CrSi	Neoprene/ EPDM	ASTM A 36,A 572 DIN ST52-3 GB/T 700-2006 GB/T1591-2008

Figure 4 – Modular bridge joint components and construction materials

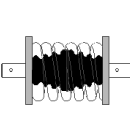

TechStar-Tegu modular bridge joint supporting system

STANDARD SINGLE BAR – LG

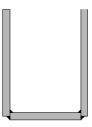
Support System

In the Single Bar – LG MEJS design, all center beams are supported by a single support bar. Elastic, pre-stressed sliding elements are contained by brackets / stirrups welded or bolted to the center beam at a spacing based on the design code applied. The same elastic, pre-stressed sliding elements are used inside the support bar boxes.)

This support system permits an optimum load transmission while attaining the flexibility to provide movement in three different directions. (See Figure 5).

Control System

Along with the elastomeric profiles, elastomeric control springs coordinate the individual movements to form a dynamic system that simultaneously absorbs braking and accelerating forces. The reaction of these controlling forces on the joint edges can be assumed to act in the direction of displacement with the following maximum values: Tension – max. 3 KN/m; Compression – max. 4 KN/m. (See Figure 6) .

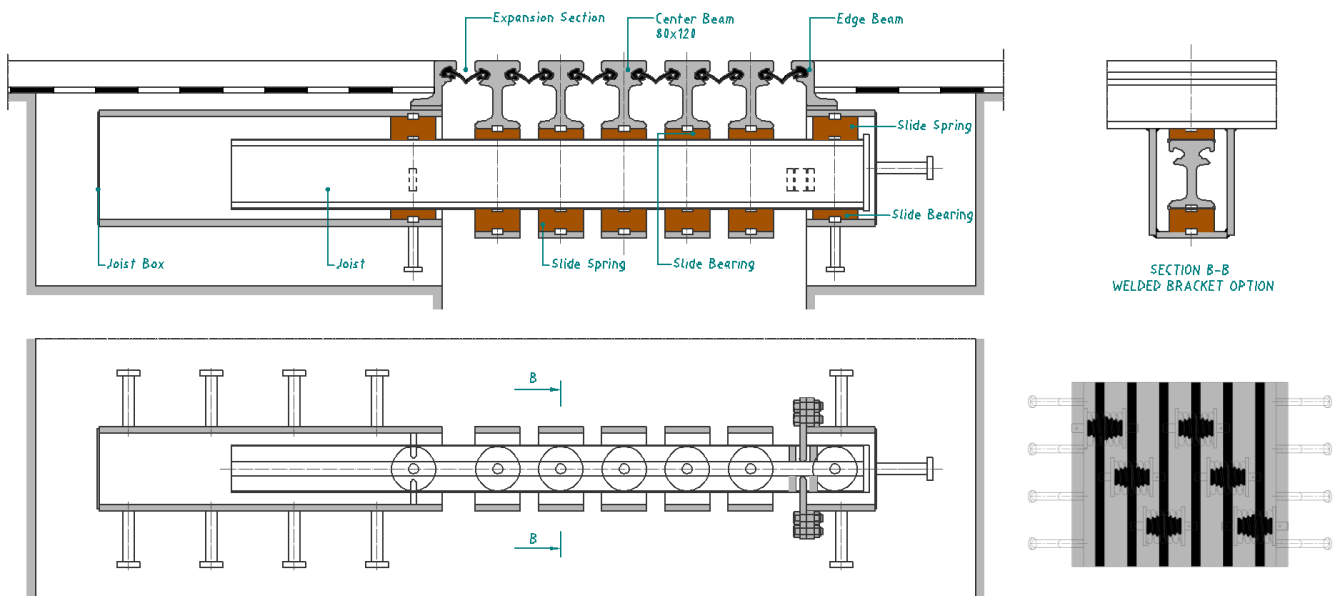

Figure 5 – Support system

SWIVEL CAPABLE EXPANSION JOINT

Transverse Movement

The Swivel Joint is designed to minimize any potential damage at the expansion joints from earthquake displacements. often these anticipated seismic displacements are beyond the normal thermal longitudinal movement capacity of the expansion joint and also anticipate transverse movements (sideways) and vertical rotations. (See Figure 6 and 7) .

By utilizing “swiveling-capable” modular expansion joints, designers are able to mitigate these problems. The extent of the swiveling (pivoting) and rotating of an expansion joint is a function of the geometry of the support bar boxes which permit movement of the support bars, trumpeting them to permit the required additional movements, and use of spherical bearings for vertical rotations. Extra-long support bars which extend beyond the normal thermal movement

Requirements Are used to accommodate Any longitudinal seismic movements. Modifications needed by these designs from normal modern modular expansion joint systems are relatively minor. Any “Single Bar” modular expansion joint is capable of swiveling

TechStar-Tegu modular joints of this type have been used on several key bridges within the “high earthquake zone” around San Francisco, California including New Transbay Terminal Project, the San Francisco Airport Interchanges, the Benicia-Martinez Bridge, the Carquinez Bridge, the San Francisco-oakland Bay Bridge, and several structures in the los Angeles freeway system. Our “Swiveling Capable” Modular Joints have been manufactured in China and exported for use to projects in Bangladesh, Dubai, and to Africa.

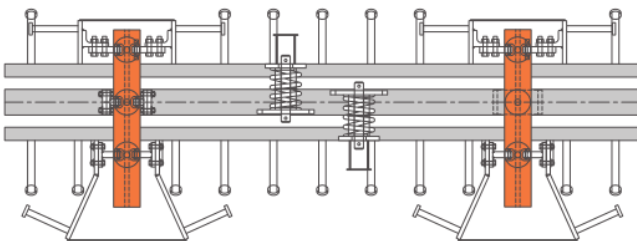

Figure 6

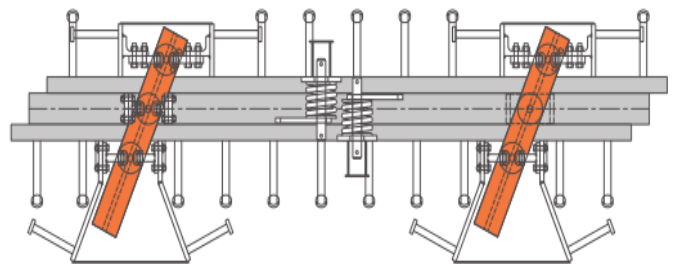
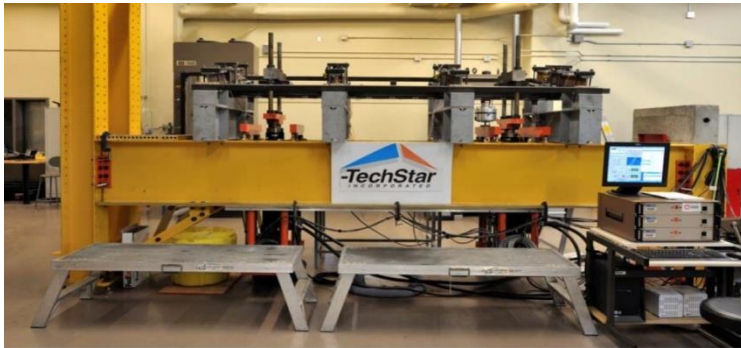

Figure 7

EXPANSION JOINT FATIGUE TESTING

Three specimens of the TechStar-Tegu Single Bar Modular Bridge Expansion Joint (MBEJ) with welded stirrups were tested in fatigue according to the requirements of the NCHRP-402 Report, the AASHTO Bridge Construction Specifications and AASHTO LRFD 1998 Bridge Design Code. The fatigue testing was carried out at the Structures laboratory at École de Technologie Supérieure, University of Quebec.



Welded Stirrups

Test results were used to produce an experimental fatigue curve of the stirrup details with all points located above the AASHTO Fatigue curve for Category C welds. Hence it can be concluded that the fatigue resistance of the welded stirrup connection detail of the TechStar-Tegu MEJS Single Bar System is compatible with (and qualifies for) the

fatigue Category C of the AASHTO LRFD 1998 Bridge Design Code. (See Figure 8).

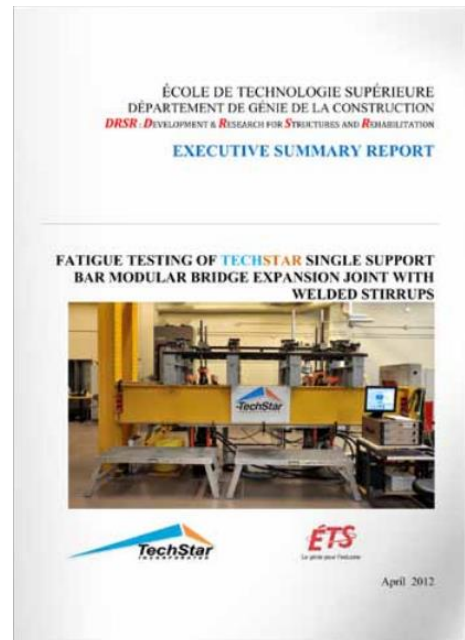
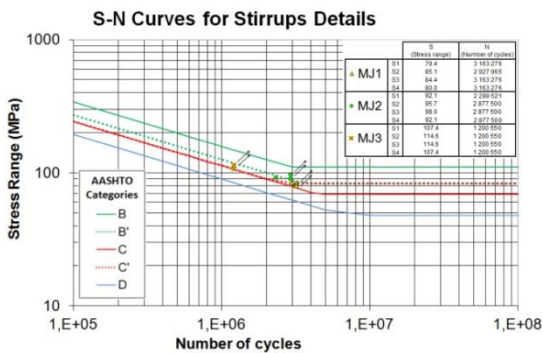

Figure 8 - Seq –N test points obtained for stirrups from Fatigue tests

DESIGN AND PHYSICAL STRENGTHS



- 1
- 2
- 4
- 5
- 3

1 Quality Control (MEJS Birth Certificate) - Tight tolerances permit long term success. TechStar –Tegu develops a checklist” of tolerances to be recorded for each joint. This checklist is like a birth certificate, it describes every step of production, every critical measurement is recorded and this document is provided to the client as proof of complete quality control.

2 Elastic Connection
 - TechStar-Tegu Modular expansion Joint Design does not weld the Center Beam to the Support Bar, instead using Elastic components, TechStar’s design creates and Elastic Connection. This eliminates a fatigue problem of welds and permits damping of the modular

joints through the elastomeric component. control.

3 Corrosion Resistance - All exposed steel components of each MEJS are protected against corrosion through sand blast cleaning and being either hot dipped galvanized or painted with an inorganic zinc paint system. Method depends on the specifications of each individual project.

4 Parallel Support Bars - TechStar-Tegu’s MEJS design has Parallel Support Bars that can be aligned with the wheel lanes. Parallel Support Bars provide sufficient clearance for concrete and reinforcing steel. Support bar spacing can be reduced for larger truck loading conditions..

5 Outside the box - TechStar-Tegu’s MEJS design accommodates easy replacement of all the smaller components such as Slide Bearings and Slide Springs. This is due to these smaller components being outside of any restrictive box, allowing accessibility for quick and easy replacement when necessary.

HE SAYS SHE SAYS – TECHSTAR-TEGU VERSUS THE COMPETITION

When it comes to Modular Expansion Joints, the competition can claim a lot of things. But just because some companies claim superior design characteristics, doesn't make them factual. Here are some of the 'claims' suppliers will peddle:

“Our Control System is flexible and less rigid than TechStar.”

Rebuttal: Most of TechStar's European competition's statements are not accurate or misleading. TechStar's joint system is no more rigid and inflexible than anyone else in the market, including our competitors from the Germanic speaking countries of Europe. Our European competitors require "limiting straps" and which are essential due to the high likelihood for their control springs failure. The shear springs will fail, as they require consistent high stresses in their elastomeric components. The rubber steel interface eventually fails in shear due to elastomer age hardening and bond breaking between the steel inserts and the rubber "spring". These failures are catastrophic and require straps to mitigate their failure. Making assemblies more complicated is not an advantage. It's just more opportunity for an individual component to fail. Where the straps are attached creates an additional fatigue failure location from its connection to the beam--one that they alarmingly avoid in their fatigue testing.

“Our Bolted connections increase fatigue resistance.”

Rebuttal: Irrespective of any lab testing, AASHTO recognizes that welded connections are preferable to bolted connections in bridge structural members and in expansion joints for support bar stirrup connections. Acceptable stress levels using Welding (category C stress level) are much higher than Bolts (category B) leading to a much lower likelihood of a failure by using welding. Bolts are subject to equal torqueing, which on the factory floor becomes unlikely in mass production. Bolt holes are drilled individually and occasionally are too close to the outer edge of the base material. This results in premature failure in the steel stirrups as fatigue



Figure 9 -- There is no more flexibility in our competitors support bar to center beam connection than in TechStar's. In most cases, TechStar's is more flexible.

HE SAYS SHE SAYS – TECHSTAR-TEGU VERSUS THE COMPETITION

cracks prolegate to the edge of the material. This risk is eliminated in the TechStar design by using welded stirrups. We have no doubt that our competitors will next be proposing using "rivets" as an advantage over welding. We are unsure which is worse, the rivets or the 3rd world sourced bolts that our competition continually uses.

“Our sliding surface technology increases sliding distance.”

Rebuttal: TechStar only uses USA produced PTFE which outperforms the 3rd world sourced sliding materials which has experienced significant problems and embarrassments from their low-wage/low-quality material supply sources. Our competition scours the world looking for the next cheaper material supply sources. This applies to our competition’s PTFE replacement material as well. USA PTFE is preferable, more consistent, and easier to confirm. TechStar tries to eliminate problems while our competitors creates them in the pursuit of their "design advantage".



Figure 10 -- AASHTO is very clear: Welded connections are more fatigue resistant than bolted connections.

“Our hump seal reduces dirt accumulation.”

Rebuttal: "Hump shaped" gland has been rejected by nearly every USA state where it was approached and attempted. . It creates a wear surface in the gland subject to tearing from traffic and the tear spreading. It also sets up compression set problems in "the hump" during joint closing that can then force the seal to "pull out" from the steel retainer when opening occurs. The V shaped gland is much preferred from actual roadway experience and long-term performance.

“Our Fuse System provides assistance during an earthquake.”

Rebuttal: The fuse and fuse box system is unnecessary and has never proved itself in field exposure to an Earthquake in a structure, anywhere. It is a gimmick with added costs and no proven benefit. This system has never been used in the USA on any structure. Instead our competition prefers to market this to clients outside of high seismic zones. This approach to structural protection is no different than the re-introduction of a "coo-coo clock" approach to measuring time. Its weights, chains, and pulleys with birds popping out hourly to justify their design. There is no proof that it works nor provides any advantage.

INSTALLATION

Assembly and Transportation

Each MEJS is completely assembled in TechStar-Tegu’s shop and set with adjustable clamps to an agreed preset opening. The MEJS can be transported to site as a one-piece structural element up to a maximum transportable length. It must be lifted only at the points indicated and well supported, preferably at the joist boxes, so that it is not twisted.



Reinforcement Connection

The structural reinforcement of the MEJS should be arranged perpendicular to the joint. The structural reinforcement is interlinked with the joint anchorages and secured with longitudinal lacing bars threaded through the anchorage loops and structural reinforcement. Welded connections between the joint anchorages and the structural reinforcement are to aid installation only. (See Figure 11)



Edge Connection

For asphalt surfacing installations, the MEJS edge beams are equipped with horizontal flanges to connect the anchorages and to affix the waterproof membrane, if required. For concrete surfacing installations, the edge beams are anchored with shear stud connectors or loop anchors. (See Figure 12)

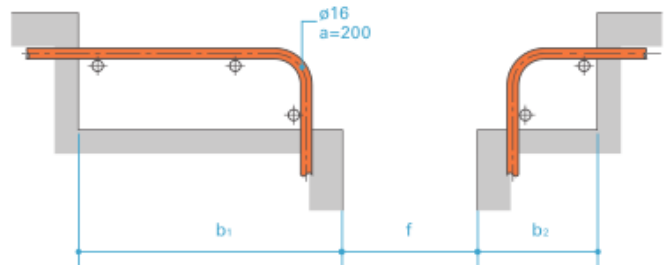

Figure 11 – Support system

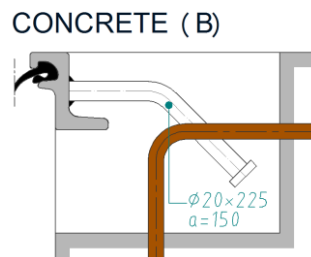
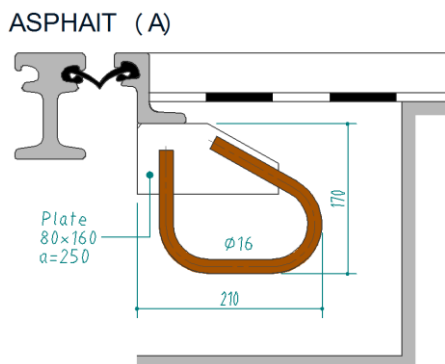
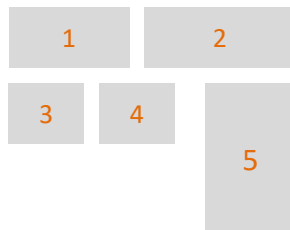

Figure 12 – Asphalt and concrete edge connection

INSTALLATION



- 1 The modular joint is lifted into the blockout.
- 2 The modular joint is suspended in the blockout by long angles bolted to the joint.
- 3 The modular joint is closed to the proper gap setting, based on the temperature and the amount of creep / shrinkage that is to occur.
- 4 After the modular joint has been properly set and the formwork is in place, the joint is ready for the concrete pour.
- 5 The modular joint is held into position by welding anchors to the back of the support bar boxes. Care must be taken not to heat the elastic components.

FINGER JOINT



Finger Type expansion joints used in bridge construction are an ideal component to accommodate bridge expansion and contraction while reducing the amount of noise pollution that occurs in other alternative joint types. The primary components of the Finger Type expansion joint consist of steel plates (sliding) that are connected to each side of the road surface's gap. Finger Joints are designed with in a (fingers of a hand) type of pattern, where the steel plates accommodate movement within one another & allow movement along the axis of the fingers themselves. Since there are no moving parts attached to the joint, cantilever moments reduce the stress induced to the structure. There is a large replaceable gutter below the joint which is made of reinforced neoprene and provides an efficient drainage system into the bridge's ducts. The gutter also limits the build up of standing water to reduce the possibility of vehicles aquaplaning.

TechStar-Tegu's finger joints reduce noise pollution. Drivers and residential and commercial real estate nearby the roads where the Finger Joints are applied can enjoy more comfort from noises that occur on the Finger Joint plates

FINGER JOINT

There are two types of TechStar Finger Joints: TechStar-Tegu Finger Joint Type A (TSF A) and TechStar-Tegu Finger Joint Type B (TSF B). TSF A has a movement capacity of 800mm while TSF B has a movement capacity of 120mm (is a noise reduction substitute for strip seal joints). In applications where effective maintenance practices are carried out then TechStar-Tegu's Finger Joints will last for a very long time and as such they offer a very cost-effective and durable solution for most bridge applications. Every Finger Joint is custom designed and fabricated to individual specifications

Finger Joint Type A (TSF A)

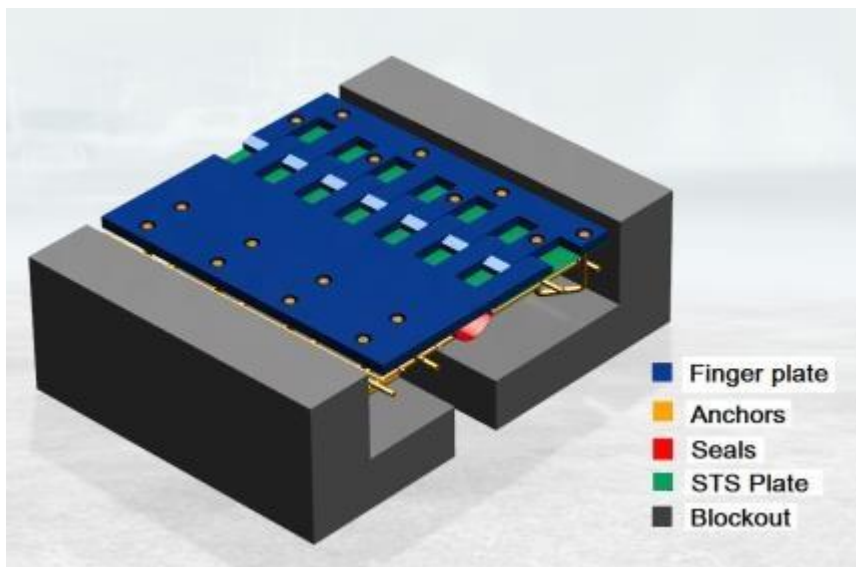

TSF A is a type of finger joint that is suitable for bridges with heavy traffic loading and movements between 100mm and 800mm. It includes a steel-rubber bonded system, which is either fixed directly to the supporting structure with chemical anchors on a prepared surface, or is bolted to a steel substructure which is concreted in place. The finger plates are pre-tensioned downwards as a result of a slight inclination at installation, and the tips of their fingers thus maintain constant contact with the sliding surface at the opposite side of the bridge gap. A watertight drainage channel beneath the joint is designed to accommodate all movements.

FINGER JOINT

Main dimensions

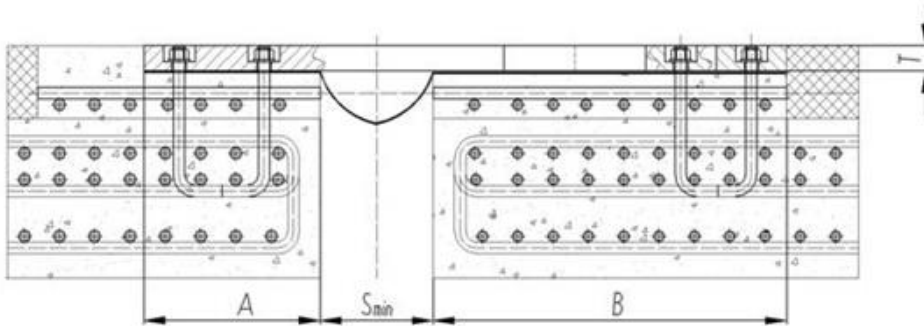

Type	Movement Capacity	Smin	A	B	T
	mm				
TSF A100	100	60	250	300	45
TSF A200	200	60	250	400	45
TSF A300	300	60	250	480	60
TSF A400	400	60	250	580	60
TSF A500	500	60	340	680	60
TSF A600	600	60	340	800	70
TSF A700	700	60	340	900	70
TSF A800	800	60	340	1000	70

■ Strengths of TSF A finger joint TSF

1. High-quality steel-rubber composite system ensures increased durability
2. Minimal installation depth; quicker and simpler installation as compared with conventional joints
3. Less influence on traffic during replacement
4. Low noise under traffic due to the design with interlocking fingers
5. High driver comfort due to the special connection and support of sliding finger plates
6. Reliable prevention of protrusion above the driving roads

FINGER JOINT

Finger Joint Type B (TSF B)

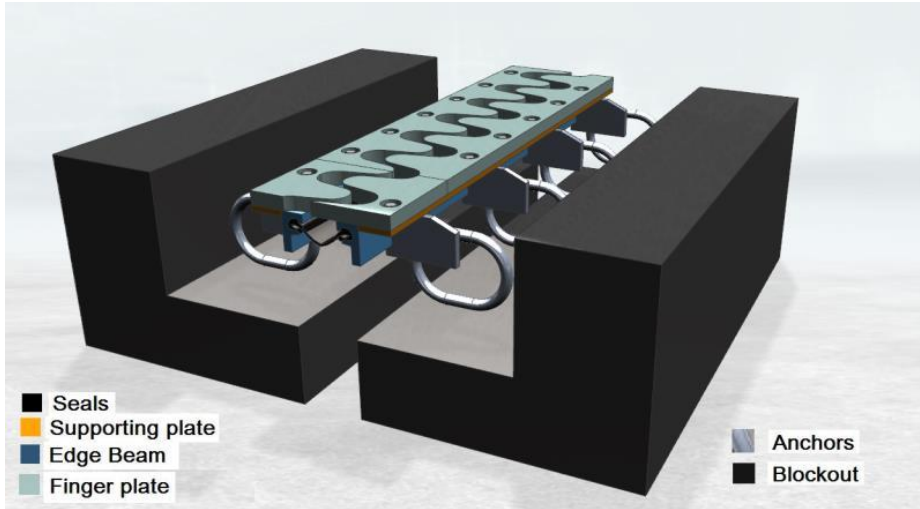

TSF B type is a finger joint (which is also named as Low Noise Strip-seal Joint) that is suitable for bridges with heavy traffic loading and movements up to 120mm. It consists as a hybrid system of both strip seal system elements and a finger-plate system. This type of finger joint provides considerably enhanced noise reduction by up to 70%. The installation of such a joint is very similar to that of a modular joint. A watertight drainage channel beneath the joint is designed to accommodate all movements.. A watertight drainage channel beneath the joint is designed to accommodate all movements.



TechStar-Tegu finger expansion joint

FINGER JOINT

Main dimensions

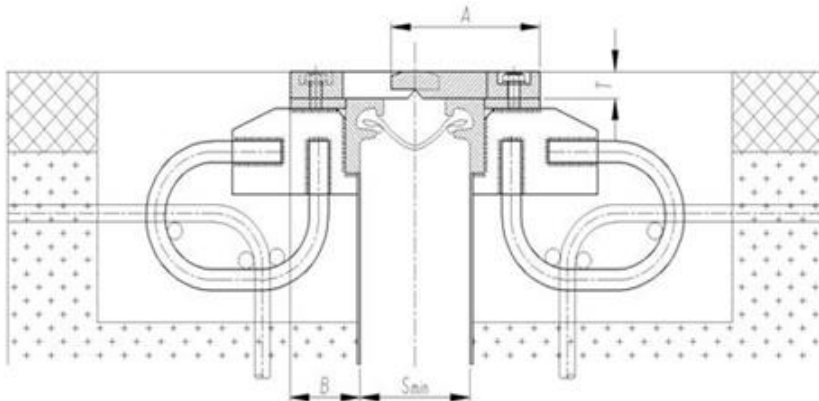

Type	Movement Capacity	Smin	A	B	T
	mm	mm	mm	mm	mm
TSF B40	40	50	95	50	25
TSF B60	60	50	115	60	25
TSF B80	80	50	135	70	25
TSF B100	100	50	155	80	25
TSF B120	120	50	175	90	25

■ Strengths of TSF B finger joint TSF

1. Take higher loading compared with strip seals
2. It is easier to do replacement or repairing compared with strip seals and less influence on traffic during replacement or repairing will occur
3. Low noise under traffic due to the design with interlocking fingers
4. High driver comfort
5. Reliable prevention of protrusion above the driving roads
6. Combination of the strengths of strip seal joints and finger joints.

NOTABLE PROJECTS



- 1
- 2
- 5
- 3
- 4

- 1 Banegas Bridge, Bolivia
- 2 Blayton Haughs Viaduct, Aberdeen, Scotland
- 3 Carquinez Bridge, California, USA
- 4 New San Francisco-Oakland Bay Bridge, California, USA
- 5 Memorial Bridge, Florida, USA

NOTABLE PROJECTS



- 1
- 2
- 3
- 4
- 5

- 1 Palm Jumeirah Bridge, Dubai, UAE
- 2 Lusail Pearl Bridge, Doha, Qatar
- 3 Rupsha Bridge, Bangladesh
- 4 Temburong Bridge CC2, Brunei
- 5 Transbay Terminal, California, USA



www.techstar-inc.com
engineering@techstar-inc.com

D.S. Techstar, Inc.
1219 west Main Cross
Street Findlay, Ohio 45840
USA
Tel: +1-419-424-0888
Fax: +1-419-424-5959